

CAM-05

CAM-05 Rain Cover



- Surface-mounted rain cover for VTO2202F

Technical Specification

Performance

Casing	Aluminum alloy
--------	----------------

General

Color	Silver
Installation	Surface mount
Dimensions	141.1 mm × 101.6 mm × 48.5 mm (5.56" × 4" × 1.91")
Protection Grade	IP65 (silicone sealant is needed)
Net Weight	309 g
Gross Weight	501 g

Dimensions (mm[inch])

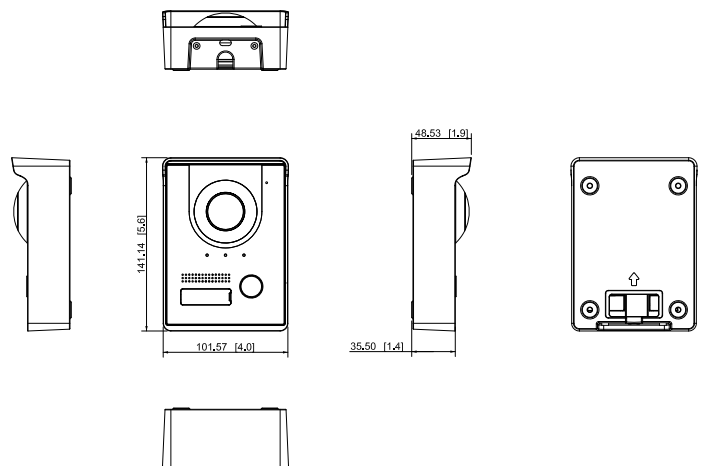

Installation

