

CAM-115

Water-proof Power Box



Features

- Material: aluminum & SECC
- IP66 power box
- Aesthetic design

Technical Specifications

Model	CAM-115
General	
Material	Aluminum & SECC
Dimension(WxHxD)	297mmx248mmx106mm (11.69"x9.76"x4.17")
Inch Thread	M20(G1/2")
Load Bearing	8.0kg (17.64lb)
Weight	3.2kg (7.05lb)
Color	White
Operating Temperature	-40°C ~ +60°C (-40°F ~ +140°F)
Humidity	0~90% RH

Dimensions (mm/inch)

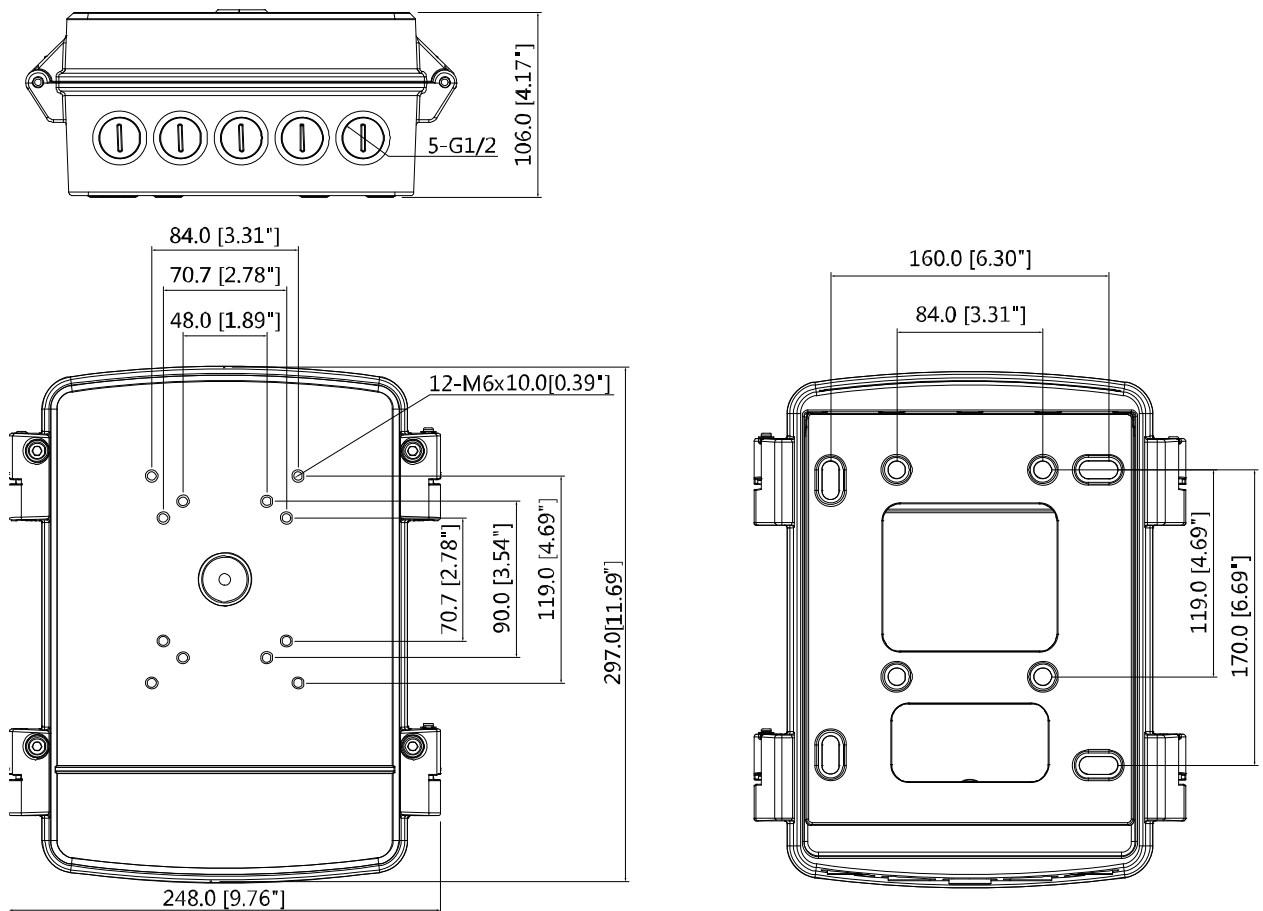

Application

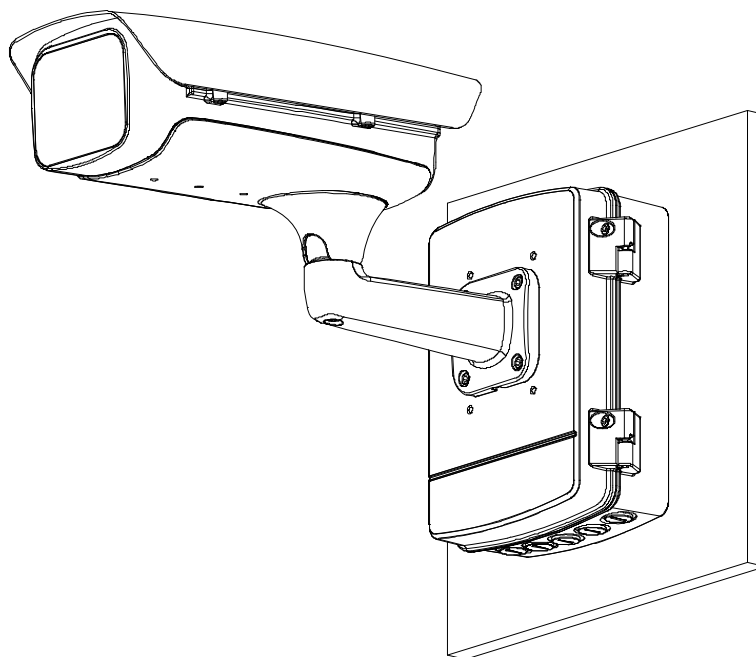

Package Information

- Power box *1
- M6x25 screw *4
- M6x14 screw *4
- M8 plastic anchor *4
- Wrench *1
- Water joint *3
- User manual *1